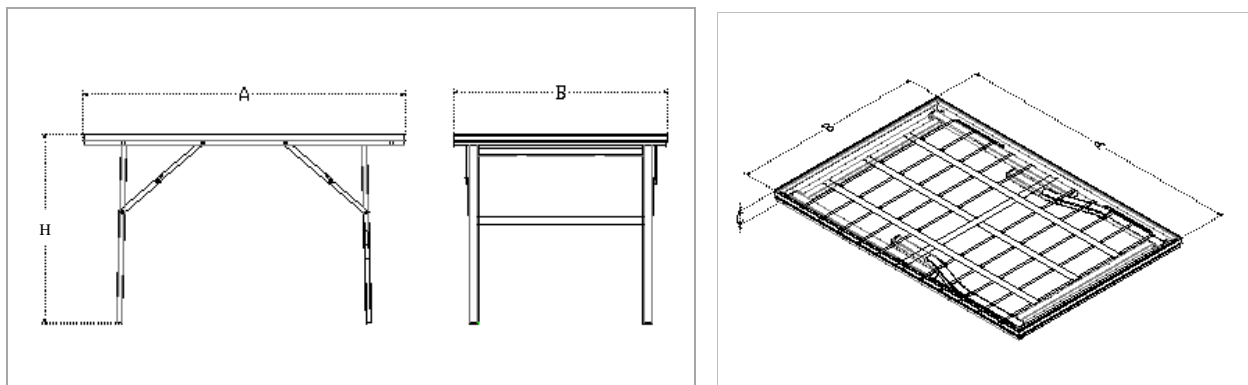

Banco pieghevole in alluminio versione base / Aluminium table folding basic version

Caratteristiche tecniche / Technical data

Codice <u>code</u>	Lunghezza <u>length</u> A (cm)	Larghezza <u>width</u> B (cm)	Altezza <u>height</u> C (cm)	Altezza <u>height</u> H (cm)	Peso <u>weight</u> (kg)	Volume <u>volume</u> (mc)
A1/5015	150	50	3	62	4,71	0.022
A1/5020	200	50	3	62	5,25	0.030
A1/6015	150	60	3	62	4,81	0.027
A1/6020	200	60	3	62	5,45	0.036
A1/7015	150	70	3	62	5,90	0.031
A1/7020	200	70	3	62	5,53	0.042
A1/8015	150	80	3	62	5,14	0.036
A1/8020	200	80	3	62	5,56	0.048
A1/1015	150	100	3	62	6,38	0.045
A1/1020	200	100	3	62	8,27	0.060
A1/1215	150	120	3	62	8,23	0.036
A1/1220	200	120	3	62	8,37	0.072

Specifica Tecnica / Technical specification

- **Profilo Montante / Mastrofile:** 30x18 mm
- **Materiale / Material:** **Lega alluminio 6060 -T5** / Alloy aluminium 6060-T5
- **Processo di saldatura / Welding process:** TIG UNI EN 9606-2:2006
- Angoli arrotondati e antitaglio/ Rounded corners and anti-cut