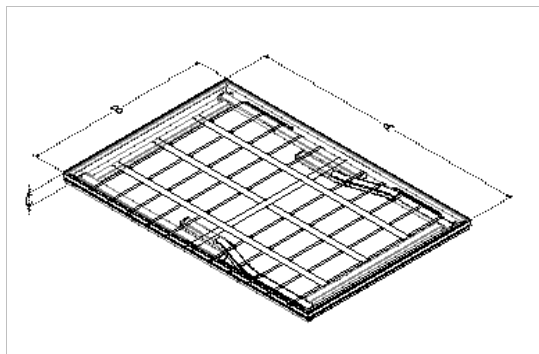
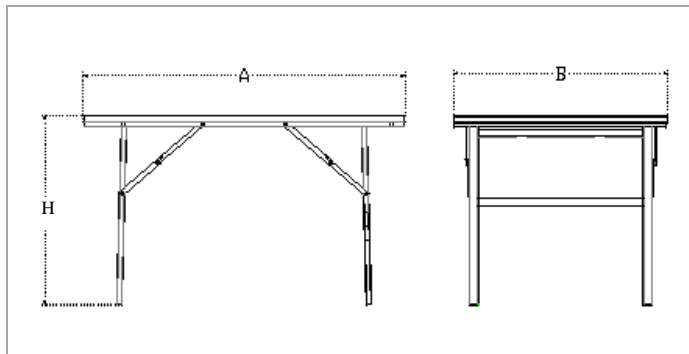

Banco pieghevole in alluminio con piano in vetroresina
Aluminium folding table, suitcase version, with fibreglass top

Caratteristiche tecniche / Technical data

Codice <u>code</u>	Lunghezza <u>length</u>	Larghezza <u>width</u>	Altezza <u>height</u>	Altezza <u>height</u>	Peso <u>weight</u>	Volume <u>volume</u>
	A	B	C	H	(kg)	(mc)
	(cm)	(cm)	(cm)	(cm)		
A2/5015	150	50	3	62	5,71	0,022
A2/5020	200	50	3	62	6,25	0,030
A2/6015	150	60	3	62	5,81	0,027
A2/6020	200	60	3	62	6,45	0,036
A2/7015	150	70	3	62	5,90	0,031
A2/7020	200	70	3	62	6,53	0,042
A2/8015	150	80	3	62	6,14	0,036
A2/8020	200	80	3	62	6,56	0,048
A2/1015	150	100	3	62	7,38	0,045
A2/1020	200	100	3	80	9,27	0,06
A2/1215	150	120	3	62	9,23	0,036
A2/1220	200	120	3	62	9,37	0,072

Specifica Tecnica / Technical specification

- **Profilo Montante** /mastrofile: 30x18 mm
- **Materiale** / Material **Lega alluminio 6060 -T5** /alloy aluminium 6060-T5
- **Processo di saldatura** / welding process: TIG UNI EN 9606-2:2006
- Angoli arrotondati e antitaglio/ Rounded corners and anti-cut